

COMICA

PROFESSIONAL AUDIO EQUIPMENT

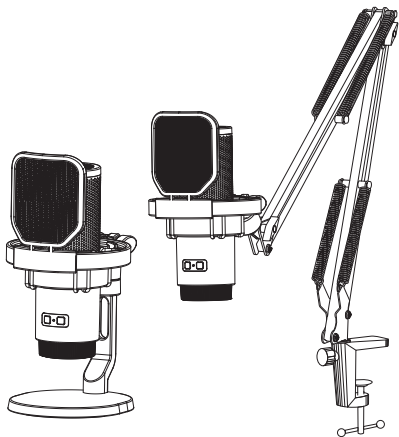

EJoy Uni

RGB Cardioid Condenser USB Microphone

User Manual

Foreword

Thanks for purchasing Comica EJoy Uni

Main Features

- 48kHz/24bit Recording, Professional Studio Quality
- Support Gain Control, Monitoring, One-key Denoise & Muting
- Dynamic Radiant RGB Light with 3 Unique RGB Effects
- USB-C Digital Output, Universal for Smartphone/Computer
- Unique Shock-mount and Metal Pop Filter
- Adjustable Boom Arm, Loading Up to 1.5kg —Uni (A)
- Equipped with Desktop Mic Stand, Flexible Extension —Uni (D)

Notice

- ⚠ Please aim the front of the microphone at the sound source to get an excellent recording
- ⚠ Do not use this equipment in the vicinity of a heat source or interference source, such as radiator, oven, refrigerator or air conditioner
- ⚠ This product is a high-precision instrument, please avoid falling, collision or pounding
- ⚠ Do not use the equipment in rain or in a damp environment to avoid short-circuit danger
- ⚠ Please store the product in a dry environment

- ⚠ When connect the mic with computer, please click sound setting and choose "Comica_EJoy Uni" as the output and input device

When connect the microphone with computer:

Sound

Output

Choose your output device

Comica_EJoy Uni

Input

Choose your input device

Comica_EJoy Uni

- ⚠ If the input sound is too loud when connected to the computer, users can adjust the computer's "Microphone Properties-Level" to reduce the gain(It cannot be adjusted on the Mac OS computer)

When connect the microphone with computer:

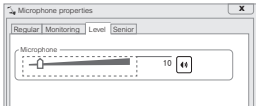

Packing List

EJoy Uni(A):

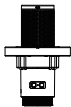

Microphone*1



Pop Filter *1



USB C-USB C/USB A
2 in 1 Audio Cable *1



Boom Arm *1



Hook and Loop
Fastener *5



User Manual *1



Warranty Card *1

EJoy Uni(D):

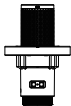

Microphone*1



Pop Filter *1



USB C-USB C/USB A
2 in 1 Audio Cable*1



Desktop Mic Stand *1



User Manual *1



Warranty Card *1

Microphone (TX) :

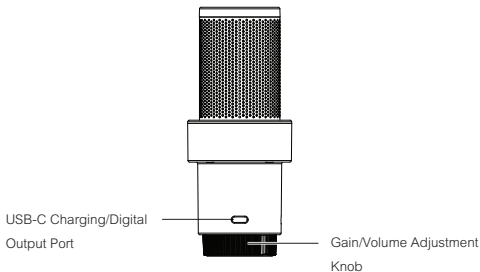
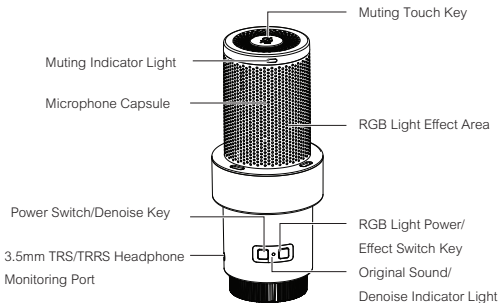

1.Muting Touch Key

Touch to adjust the Microphone normal pick up or muting status.

2.Muting Indicator Light

Red light keeps on when muting is on, no light will on when muting is off.

3.Microphone Capsule

4.RGB Light Effect Area

5.Power Switch/Denoise Key

Long press to turn the power on / off; short press to turn denoise on / off

6.RGB Light Power/Effect Switch Key

Long press to turn light power on/ off;short press to switch breathing light/dynamic gradient/ audio dynamics three kinds of light effects

7.Original Sound/Denoise Indicator Light

When the mic is turned on, blue light will on in the original sound state; green light will on in the denoise state

8.3.5mm TRS/TRRS Headphone Monitoring Port

Plug in 3.5mm TRS/TRRS headphones for real-time monitoring

9.USB-C Charging/Digital Output Port

Charging the Mic with a rechargeable battery/DC power supply via the 2 in 1 charging/output cable, or Connect to devices for audio output

10.Gain/Volume Adjustment Knob

Taking the orange scale in the center as a standard, rotate left to decrease the mic gain and headphone monitoring volume; rotate right to increase the mic gain and headphone monitoring volume

Install the boom arm:

1. Clamp the stand base of boom arm to the desktop or other objects, then tighten the fixing clip clockwise.



2. Connect the boom arm to the stand base, adjust the angle of boom arm through the fixing clip on stand base.

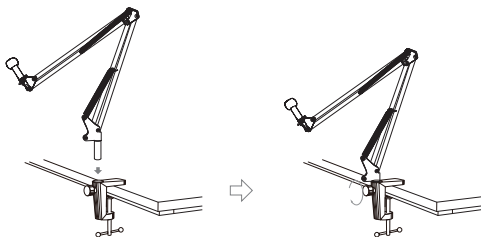

3. Connect the mic shock-mount to the boom arm, then tighten the fixing clockwise.

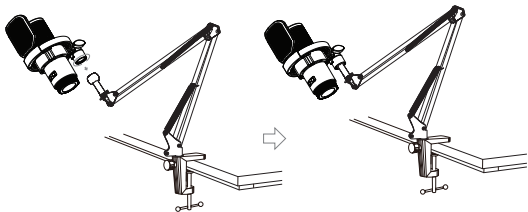

4. Adjust and fix the mic through the locking screw on boom arm.

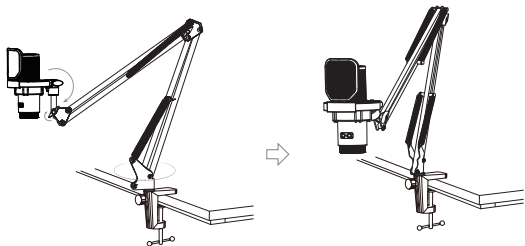

Install the desktop mic stand:

1. Connect the threaded hole of the shock-mount to the thread of the desktop mic stand, turn clockwise to tighten and fix



2. Install the pop filter on the shock-mount

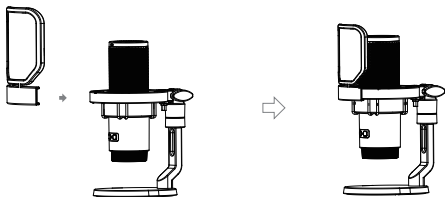

3. Adjust and fix the shock-mount and mic through the locking screw

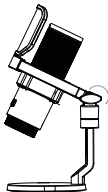

Usage:

Connected the mic with smartphone/computer through 2 in 1 audio cable and related audio adapter cable/adapter; Choose whether to monitor according to your needs

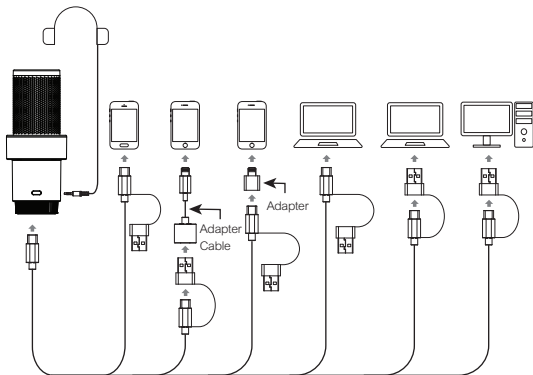

1. Please purchase USB-Lightning Adapter Cables/Adapters support OTG function by yourself when connected with lightning port devices
2. The mic will automatically switch on when connected with a device, and it will automatically turn off when disconnected from a device

Specifications

Directivity	Cardioid
Microphone Sensivity	-35dB±2dB
Frequency Range	20Hz ~ 20kHz
Maximum SPL	105dB (@ 1% THD)
Signal / Noise	72dB SPL(A-weighted,as per IEC651)
Equivalent Noise	22dB SPL(A-weighted,as per IEC651)
Dynamic Range	83dB SPL(A-weighted,as per IEC651)
Sampling Rate	48kHz
Bit Depth	Microphone Recording: 24-bit Headphone Monitoring: 16-bit
Output Interface	USB-C
Monitoring Port	3.5mm TRS/TRRS
Net Weight	Microphone Body: 121g
Dimension	Microphone Body: Φ 64.5 x L154.2mm
Operating Temperature	0°C ~ +50°C
Storage Temperature	-20°C ~ +60°C



Website: comica-audio.com

Facebook: Comica Audio Tech Global

Instagram: Comica Audio

YouTube: Comica Audio

COMICA is a registered trademark owned by Commlite Tech Co.,Ltd

Email: support@comica-audio.com

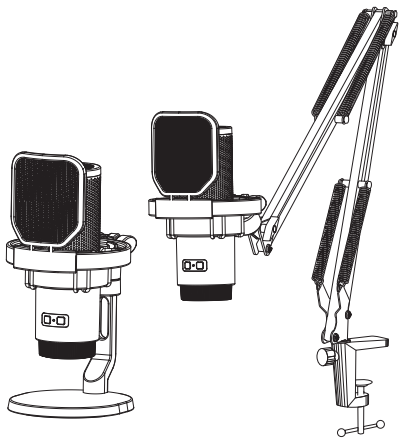

享听Uni
RGB·心型电容USB麦克风

产品使用说明书

感谢您购买科唛享听Uni

产品主要功能

- 48kHz/24bit录音，专业棚级音质
- 增益调节，实时监听，一键降噪及静音
- RGB动态灯效，3种灯效模式选择
- USB-C数字输出，通用于手机、电脑
- 独特减震架及金属防喷罩，有效滤除噪音
- 可调节悬臂支架，承重高达1.5kg—Uni (A)
- 搭配圆盘支架，可灵活延展及组合—Uni (D)

注意事项

- ⚠ 为获得更好的录音效果，请将麦克风的正面对准音源
- ⚠ 请勿将本设备放置在热源或干扰源附近使用，如散热器、烤箱、冰箱、空调等
- ⚠ 本产品属于高精密度仪器类产品，请避免使用时掉落、碰撞或重击
- ⚠ 不要在雨中或潮湿的环境中使用该设备，否则会有短路的危险
- ⚠ 请在干燥环境中对该产品进行保存
- ⚠ 当麦克风连接电脑使用时，请打开声音设置界面选择“Comica_EJoy Uni”为输出和输入设备

麦克风连接电脑使用时：



- ⚠ 若连接电脑输入时声音偏大，可以调节电脑“麦克风属性-级别”降低增益 (Mac OS 系统电脑无法调节)，下面以Windows电脑为例

麦克风连接电脑使用时：



享听Uni(A):

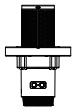

麦克风(TX)*1



防喷罩 *1



USB C-USB C/USB A
二合一音频连接线 *1



悬臂支架 *1



魔术贴 *5



说明书 *1



保修卡 *1

享听Uni(D):

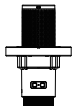

麦克风(TX)*1



防喷罩 *1



USB C-USB C/USB A
二合一音频连接线 *1



圆盘支架 *1



说明书 *1



保修卡 *1

麦克风:

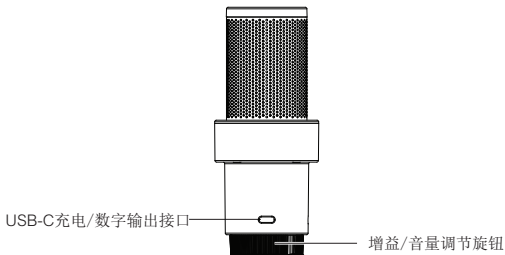
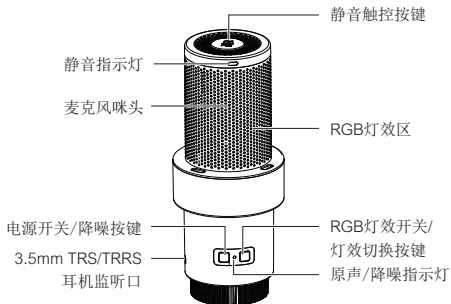

1. 静音触控按键

轻触切换麦克风正常拾音或静音状态

2. 静音指示灯

静音开启后红灯长亮，静音关闭后指示灯熄灭

3. 麦克风味头

4. RGB灯效区

5. 电源开关/降噪按键

长按开机或关机；短按开启或关闭降噪功能

6. RGB灯效开关/灯效切换按键

长按开启或关闭灯光效果；短按切换呼吸灯/动态渐变/音频动态三种灯光效果

7. 原声/降噪指示灯

麦克风开启后原声状态下蓝灯长亮；降噪状态下绿灯长亮

8. 3.5mm TRS/TRRS耳机监听口

可插入3.5mmTRS/TRRS耳机进行实时监听

9. USB-C充电/数字输出接口

可通过二合一充电/输出连接线连接充电宝/DC电源进行充电，或连接设备输出音频

10. 增益/音量调节旋钮

以中间橙色刻度线为标准，往左旋转减小麦克风增益及耳机监听音量；往右旋转增大麦克风增益及耳机监听音量

安装悬臂支架:

1. 将悬臂支架底座的固定夹夹在桌面或其他物体上，顺时针拧紧固定



2. 将固定夹与悬臂支架相连，通过底座上的固定螺丝钮来调整支架的角度

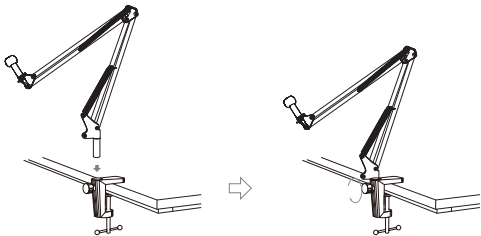

3. 将麦克风减震架与悬臂支架相连，顺时针旋转拧紧固定

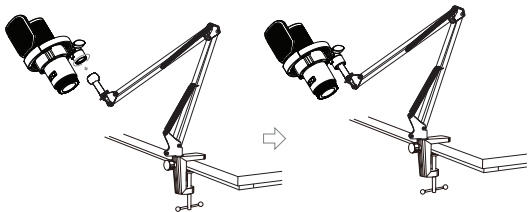

4. 通过悬臂支架上的锁紧螺杆来调整和固定麦克风的位置

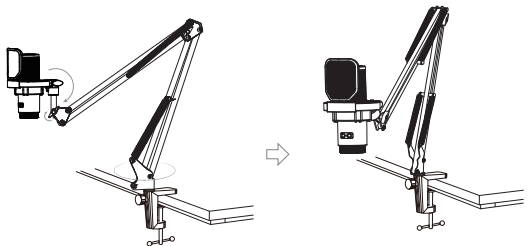

安装圆盘支架：

1. 将减震架的螺纹孔与圆盘支架的螺纹相连，顺时针旋转拧紧固定。



2. 将防喷罩安装在减震架上

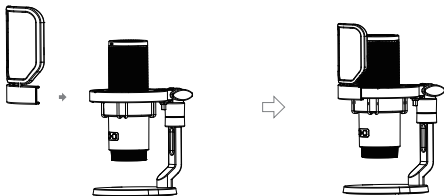

3. 通过减震架上的锁紧螺杆来调整并固定减震架与麦克风的位置

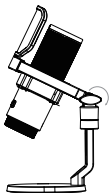

使用

通过二合一充电/输出连接线和相关音频转接线/转接头连接麦克风和手机/电脑，根据个人需求选择是否监听

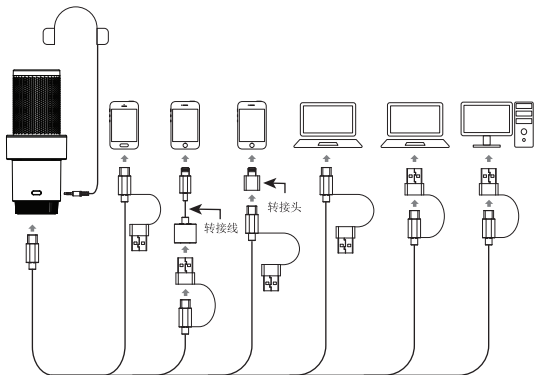

1. 搭配Lightning接口设备时，请自行购买支持OTG功能的USB-Lightning转接线/转接头
2. 麦克风连接设备后会自动开机；断开设备后会自动关机

规格参数

指向性	心型指向
咪头灵敏度	-35dB±2dB
频率范围	20Hz ~ 20kHz
最大声压级	105dB (@ 1% THD)
信噪比	72dB SPL(A-weighted,as per IEC651)
等效噪声	22dB SPL(A-weighted,as per IEC651)
动态范围	83dB SPL(A-weighted,as per IEC651)
采样率	48kHz
位深	麦克风录音：24-bit 耳机监听：16-bit
输出接口	USB-C
监听接口	3.5mm TRS/TRRS
产品重量	麦克风主体：121g
产品尺寸	麦克风主体：Φ64.5 x L154.2mm
工作温度	0℃~+50℃
储存温度	-20℃~+60℃



扫二维码关注
科唛官方公众号



COMICA科唛



COMICA科唛



COMICA科唛



COMICA科唛

邮箱: support@comica-audio.com

电话: 400-8303-981

网址: comica-audio.com

版权及科唛商标归味莱科技有限公司所有